

仅供参考

REV.	REVISION RECORD	DATE
A0	新图面发行	2017.06.16

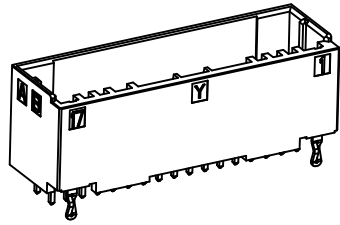

Specifications:
 Voltage Rating : 250V AC/DC
 Current Rating : 3A AC,DC
 Withstand Voltage : 1500V AC/minute
 Contact Resistance : 40mΩ(MAX.)
 Insulation Resistance : 1000MΩ(MIN.)
 Temperature Range : -55°C~+105°C

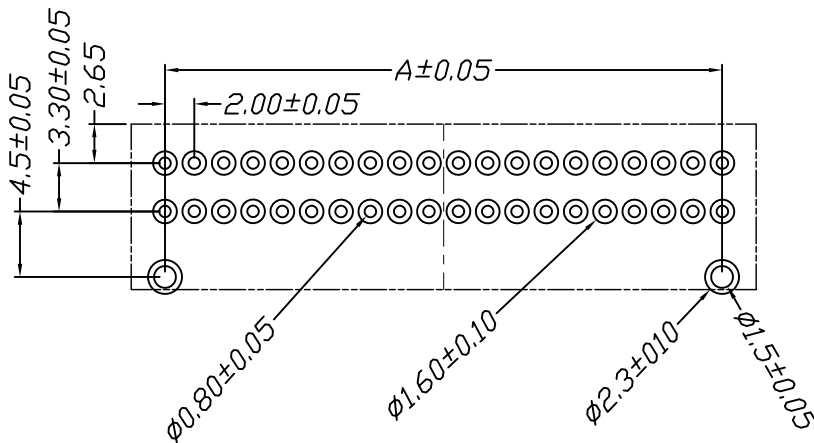
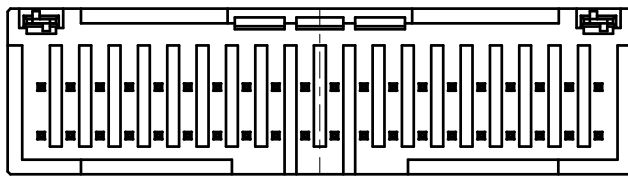
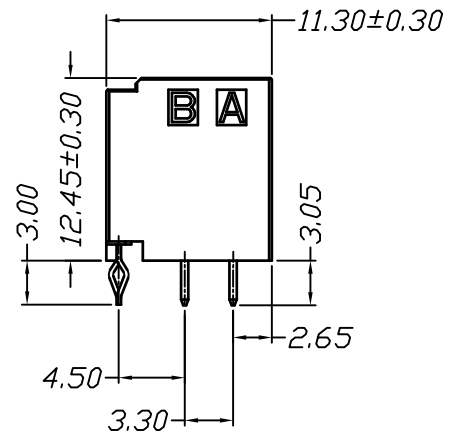
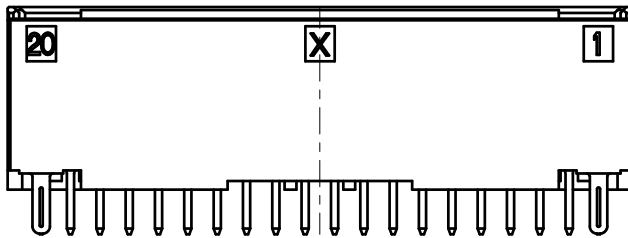
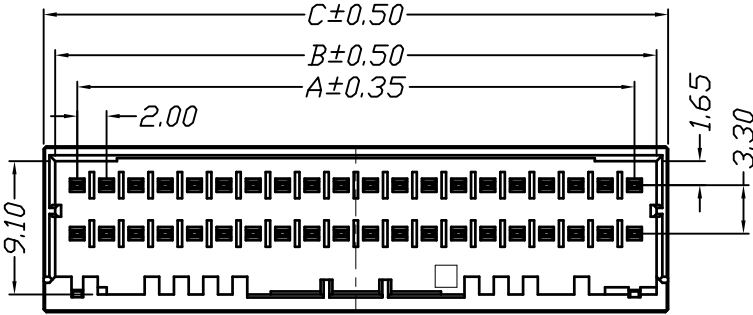

Poles	Dimensions		
	A	B	C
2*5P	8.00	11.00	12.60
2*10P	18.00	21.00	22.60
2*11P	20.00	23.00	24.60
2*13P	24.00	27.00	28.60
2*14P	26.00	29.00	30.60
2*15P	28.00	31.00	32.60
2*16P	30.00	33.00	34.60
2*17P	32.00	35.00	36.60
2*20P	38.00	41.00	42.60

P.C.B. LAYOUT

Material	Color	PIN Material	Stator Material
PBT,UL94V-0	Black	Bronze/Gold & Tin	Brass/Tin-plated

	GENERAL TOLERANCES		SCALE: 1:1	NAME	DATE
	LINEAR	ANGLES	APPROVED		
	0.0±0.35	X° REF±6°	DESIGNER		
UNIT: MM	0.00±0.25	X° ±3°	DRAWN	肖坤权	2017.06.16
SIZE: A4	0.000±0.15	X° X'±2°			

深圳市思拓展电子有限公司
 SHENZHEN SINOTOP ELECTRONICS CO., LTD
 公司网址: www.szsituo.cn 公司电话: 0755-23765350
 邮箱: 2850175982@qq.com 公司传真: 0755-23765341

TITLE:
2.00mm Pitch 180° Dula Wafer DIP Type

PART. NO:	STP42001W00-2XNPA-A1-01		
DWG. NO:			
REV:	A0	SHEET:	1/1

仅供参考

REV.	REVISION RECORD	DATE
A0	新图面发行	2017. 06. 16

Specifications:
 Voltage Rating : 250V AC/DC
 Current Rating : 3A AC,DC
 Withstand Voltage : 1500V AC/minute
 Contact Resistance : 40mΩ(MAX.)
 Insulation Resistance : 1000MΩ(MIN.)
 Temperature Range : -55°C~+105°C

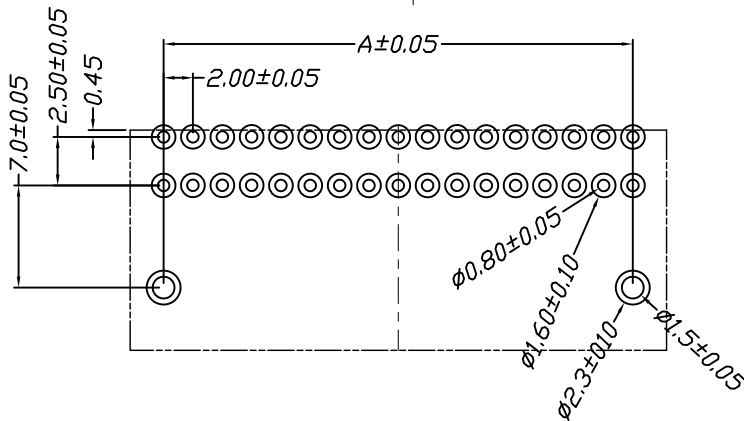
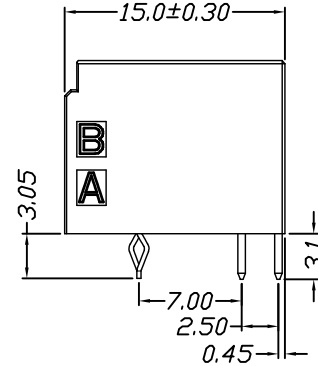
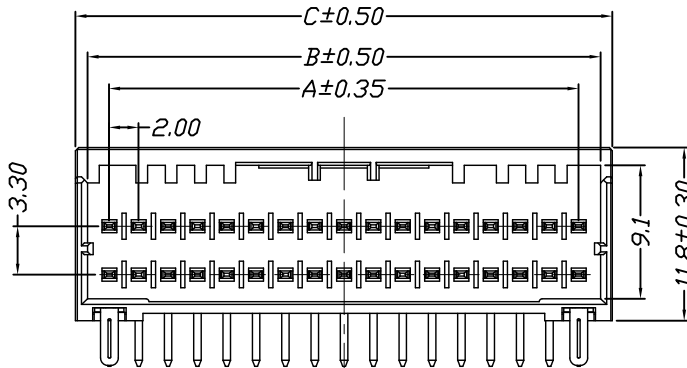
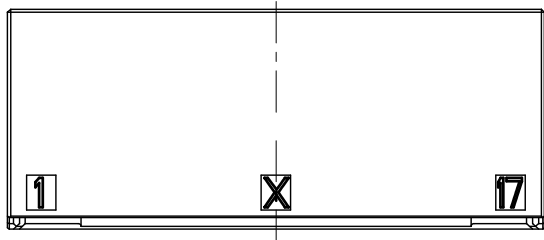
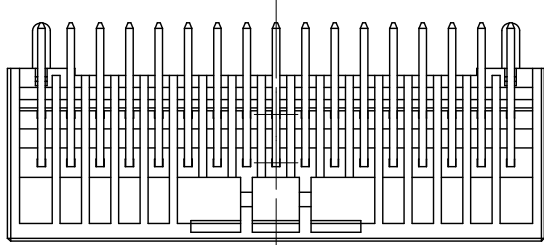
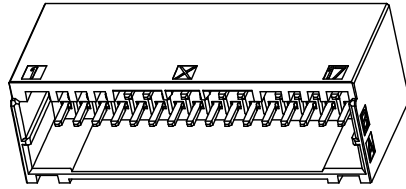

Recommended PCB pattern

Poles	Dimensions		
	A	B	C
2*5P	8.00	11.00	12.60
2*10P	18.00	21.00	22.60
2*11P	20.00	23.00	24.60
2*13P	24.00	27.00	28.60
2*14P	26.00	29.00	30.60
2*15P	28.00	31.00	32.60
2*16P	30.00	33.00	34.60
2*17P	32.00	35.00	36.60
2*20P	38.00	41.00	42.60

Material	Color	PIN Material	Stator Material
PBT,UL94V-0	Black	Bronze/Gold & Tin	Brass/Tin-plated

	GENERAL TOLERANCES		SCALE: 1:1	NAME	DATE
	LINEAR	ANGLES			
	0.0 ± 0.35	X° REF ± 6°	APPROVED		
UNIT: MM	0.00 ± 0.25	X° ± 3°	DESIGNER		
SIZE: A4	0.000 ± 0.15	X° X' ± 2°	DRAWN	肖坤权	2017. 06. 16

深圳市思拓展电子有限公司
 SHENZHEN SINOTOP ELECTRONICS CO., LTD
 公司网址: www.szstuo.cn 公司电话: 0755-23765350
 邮箱: 2850175982@qq.com 公司传真: 0755-23765341

TITLE:
2.00mm Pitch 90° DuLa Wafer DIP Type

PART. NO:	STP42001W00-2XNPA-A1-01	
DWG. NO:		
REV:	A0	SHEET: 1/1

仅供参考

REV.	REVISION RECORD	DATE
A0	新图面发行	2017.06.16

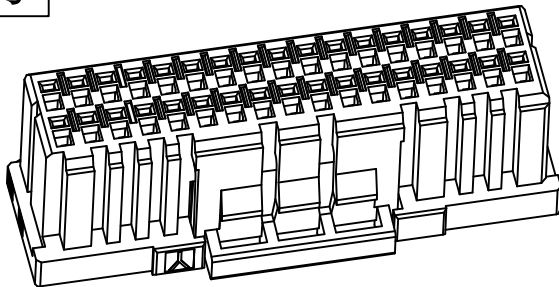

Specifications:
 Voltage Rating : 250V AC/DC
 Current Rating : 3A AC,DC
 Withstand Voltage : 1000V AC/minute
 Contact Resistance : 40mΩ(MAX.)
 Insulation Resistance : 1000MΩ(MIN.)
 Temperature Range : -55°C~+105°C

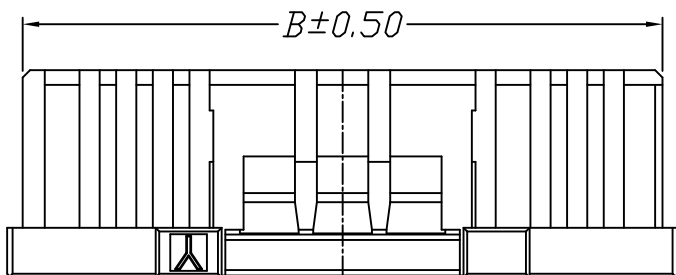
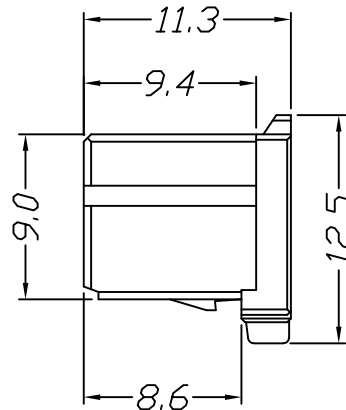
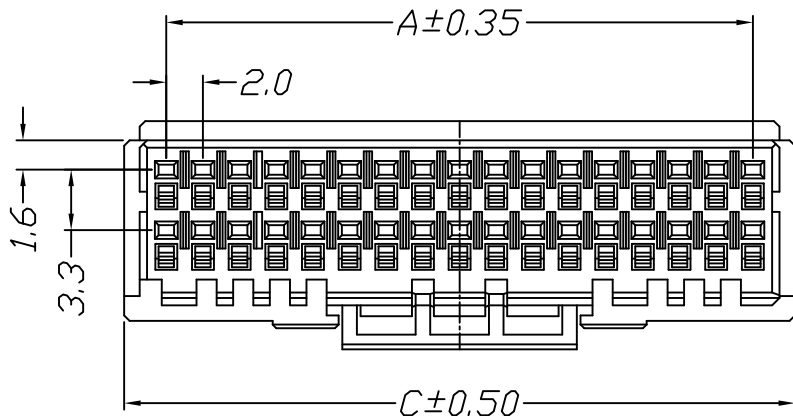
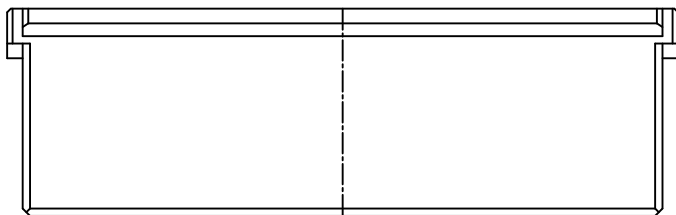

Poles	Dimensions		
	A	B	C
2*5P	8.00	10.90	12.60
2*10P	18.00	20.90	22.60
2*11P	20.00	22.90	24.60
2*13P	24.00	26.90	28.60
2*14P	26.00	28.90	30.60
2*15P	28.00	30.90	32.60
2*16P	30.00	32.90	34.60
2*17P	32.00	34.90	36.60
2*20P	38.00	40.90	42.60

Material	Color
PBT UL94V-0	BLACK

	GENERAL TOLERANCES		SCALE: 1:1	NAME	DATE	深圳市思拓展电子有限公司 SHENZHEN SINOTOP ELECTRONICS CO., LTD 公司网址: www.szstuo.cn 公司电话: 0755-23765350 邮箱: 2850175982@qq.com 公司传真: 0755-23765341	PART. NO: STP42001H00-2XNPA-PT
	LINEAR	ANGLES					
UNIT: MM	0.0±0.25	X° REF±6°	DESIGNER			TITLE: 2.00mm PITCH Housing	DWG. NO:
SIZE: A4	0.000±0.15	X° X'±2°	DRAWN	肖坤权	2017.06.16		REV: A0 SHEET: 1/1

仅供参考

REV.	REVISION RECORD	DATE
A0	新图面发行	2017.06.16

Specifications:
 Voltage Rating : 250V AC/DC
 Current Rating : 3A AC,DC
 Withstand Voltage : 1000V AC/minute
 Contact Resistance : 40mΩ(MAX.)
 Insulation Resistance : 1000MΩ(MIN.)
 Temperature Range : -40°C~+105°C

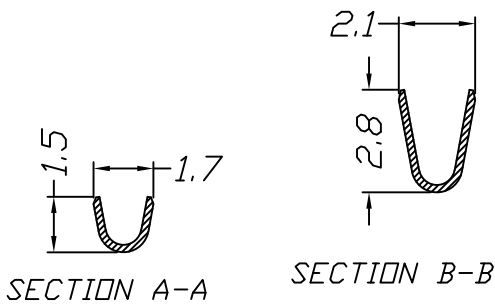
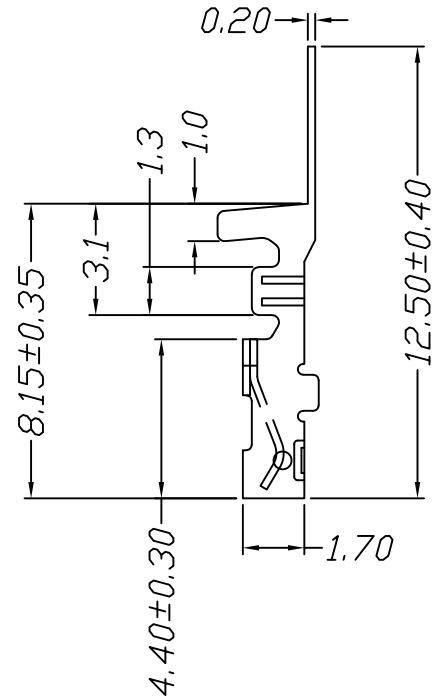
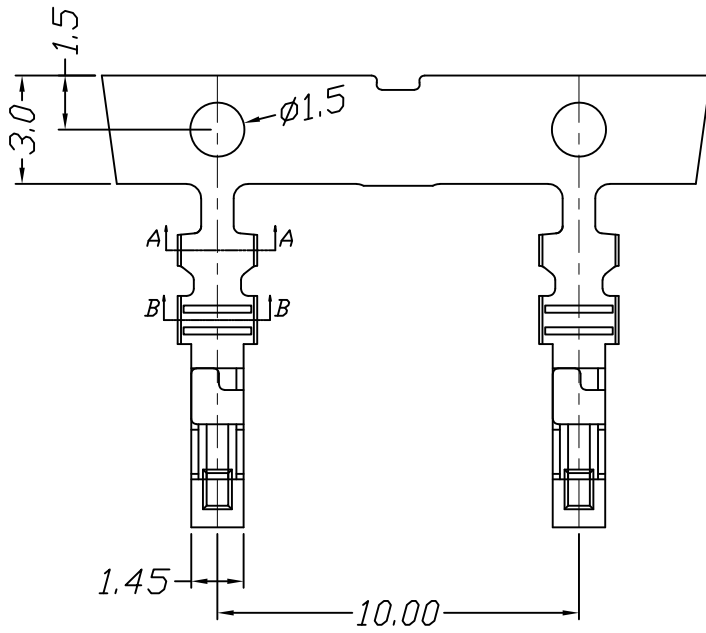

Wire Range	Insulation O. D.	Material	Finish	Qty/Reel
AWG #22~#28	1.00mm(max)	Phosphor bronze	Au or Sn	

	GENERAL TOLERANCES		SCALE: 1:1	NAME	DATE	深圳市思拓展电子有限公司 SHENZHEN SINOTOP ELECTRONICS CO., LTD 公司地址: www.szsituo.cn 公司电话: 0755-23765350 邮箱: 2850175982@qq.com 公司传真: 0755-23765341	PART. NO: STP42001TOP-**-B
	LINEAR	ANGLES	APPROVED				DWG. NO:
UNIT: MM	0.00±0.25	X° REF±6°	DESIGNER			TITLE: 2.00mm PITCH Terminal	REV: A0 SHEET: 1/1
SIZE: A4	0.000±0.15	X° X'±2°	DRAWN	肖坤权	2017.06.16		

仅供参考

REV.	REVISION RECORD	DATE
A0	新图面发行	2017.06.16

Specifications:
 Voltage Rating : 250V AC/DC
 Current Rating : 3A AC,DC
 Withstand Voltage : 1000V AC/minute
 Contact Resistance : 40mΩ(MAX.)
 Insulation Resistance : 1000MΩ(MIN.)
 Temperature Range : -55°C~+105°C

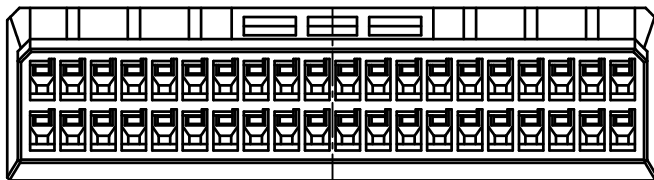
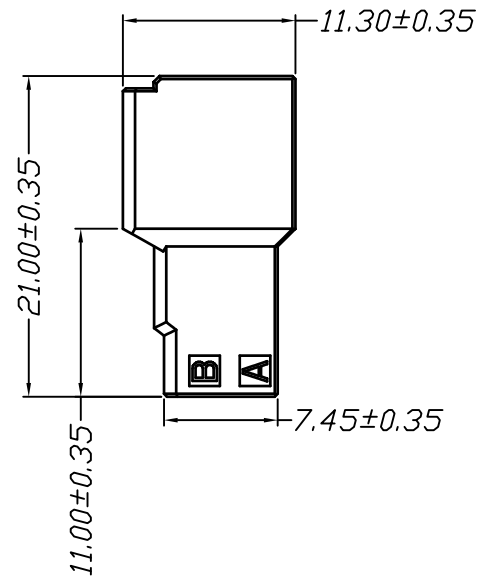
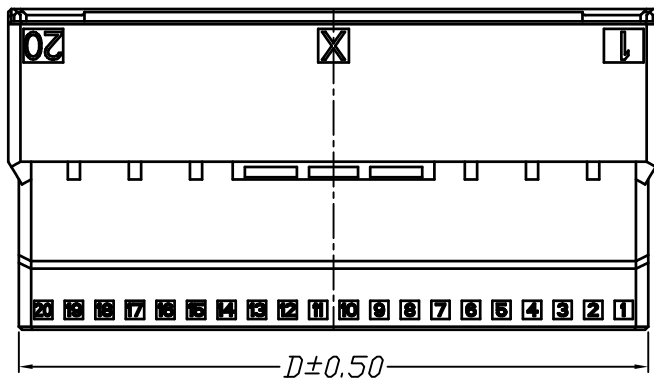
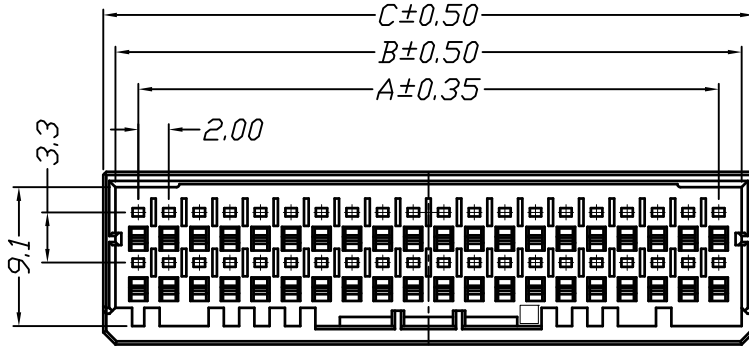

Poles	Dimensions			
	A	B	C	D
2*5P	8.0	11.0	12.6	11.2
2*10P	18.0	21.0	22.6	21.2
2*11P	20.0	23.0	24.6	23.2
2*13P	24.0	27.0	28.6	27.2
2*14P	26.0	29.0	30.6	29.2
2*16P	30.0	33.0	34.6	33.2
2*17P	32.0	35.0	36.6	35.2
2*20P	38.0	41.0	42.6	41.2

Material	Color
PBT UL94V-0	BLACK

	GENERAL TOLERANCES		SCALE: 1:1	NAME	DATE	深圳市思拓展电子有限公司 SHENZHEN SINOTOP ELECTRONICS CO., LTD 公司网址: www.szstuo.cn 公司电话: 0755-23765350 邮箱: 2850175982@qq.com 公司传真: 0755-23765341	PART. NO:	
	LINEAR	ANGLES					APPROVED	STP42001H00-2XNPA-2-PT
	0.0±0.35	X° REF±6°	DESIGNER	DWG. NO:				
UNIT: MM	0.00±0.25	X° ±3°	DRAWN	肖坤权	2017.06.16	TITLE:	REV: A0 SHEET: 1/1	
SIZE: A4	0.000±0.15	X° X'±2°				2.00mm PITCH Housing		

仅供参考

REV.	REVISION RECORD	DATE
A0	新图面发行	2017.06.16

Specifications:
 Voltage Rating : 250V AC/DC
 Current Rating : 3A AC,DC
 Withstand Voltage : 1000V AC/minute
 Contact Resistance : 40mΩ(MAX.)
 Insulation Resistance : 1000MΩ(MIN.)
 Temperature Range : -40°C~+105°C

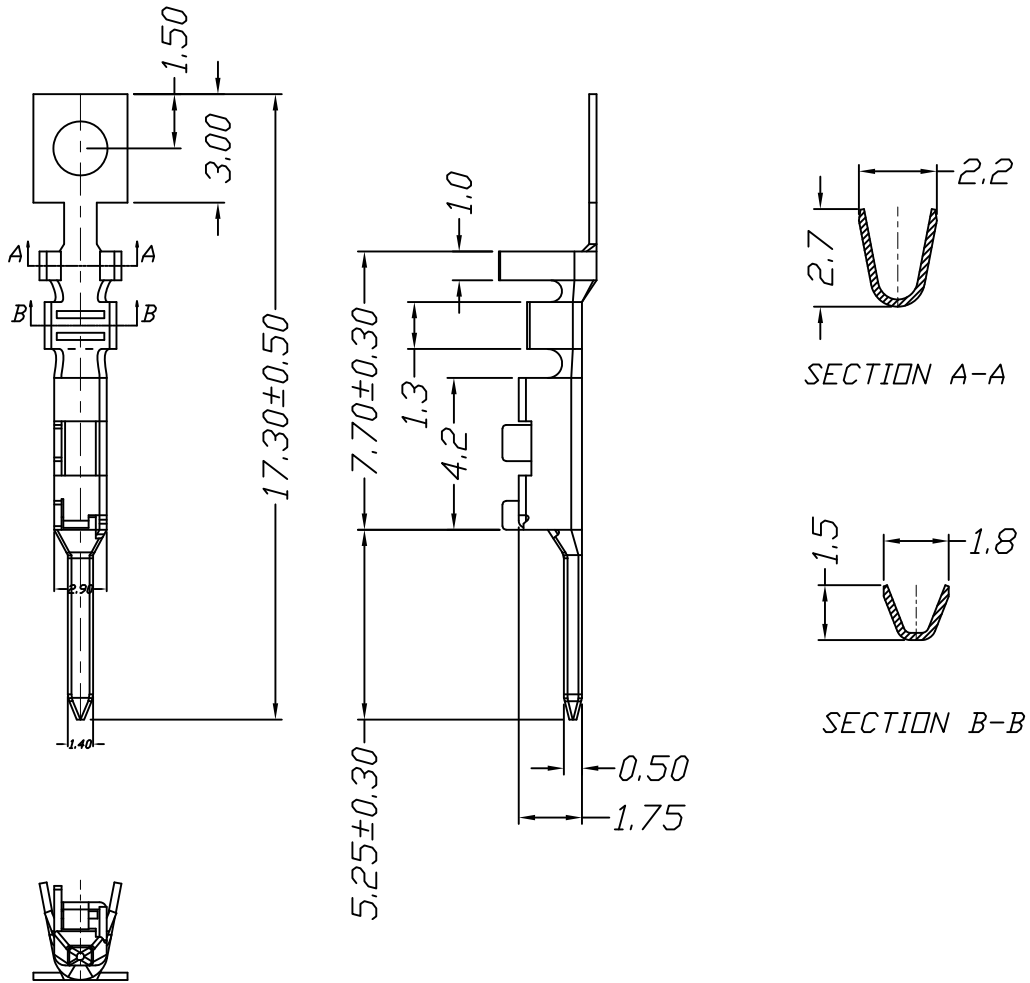

Wire Range	Insulation O.D.	Material	Finish	Qty/Reel
AWG #22~#28	1.00mm(max)	Phosphor bronze	Au or Sn	

	GENERAL TOLERANCES		SCALE: 1:1	NAME	DATE	深圳市思拓展电子有限公司 SHENZHEN SINOTOP ELECTRONICS CO., LTD 公司网址: www.szstuo.cn 公司电话: 0755-23765350 邮箱: 2850175982@qq.com 公司传真: 0755-23765341	PART. NO: STP32001TXP-XX-X
	LINEAR	ANGLES	APPROVED				DWG. NO:
UNIT: MM	0.00±0.35	X° REF±6°	DESIGNER			TITLE: 2.00mm PITCH Crimp Terminal	REV: A0 SHEET: 1/1
SIZE: A4	0.000±0.15	X° X'±2°	DRAWN	肖坤权	2017.06.16		

A B C D E F G H