

仅供参考

REV.	REVISION RECORD	DATE
A0	新图面发行	2017.06.16

主要技术参数 Main Specifications

- 线数 (Poles): 02 to 14
- 接触电阻 (Contact resistance):  $\leq 20\text{m}\Omega$
- 绝缘电阻 (Insulation resistance):  $\geq 1000\text{M}\Omega$
- 额定电压 (Rated voltage): 250V AC DC
- 额定电流 (Rated current): 5.0A AC DC
- 耐电压 (Withstand Voltage): 1500V AC/minute
- 温度范围 (Temperature Range):  $-25^{\circ}\text{C} \sim +85^{\circ}\text{C}$

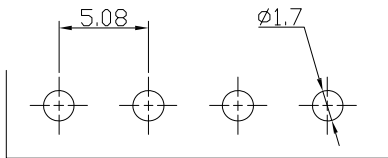
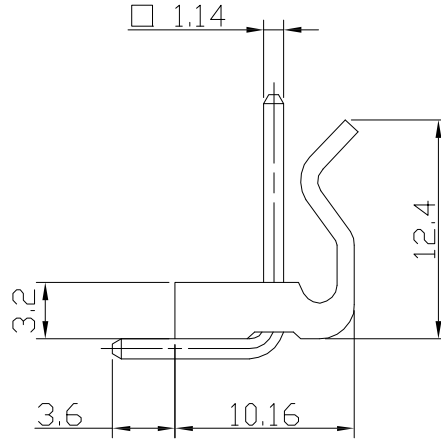
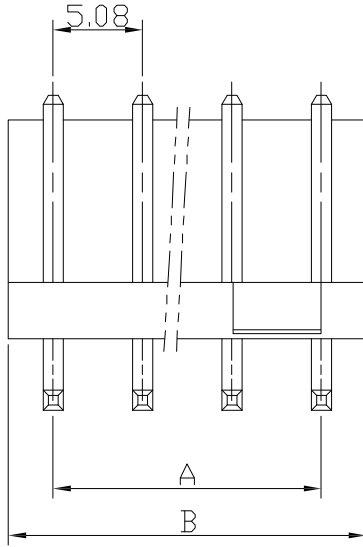
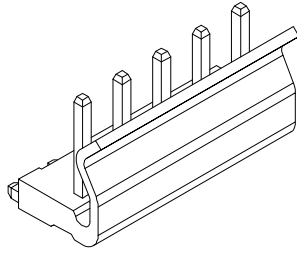

P. C. B LAYOUT

Poles	Dimensions mm	
	A	B
2	5.08	10.16
3	10.16	15.24
4	15.24	20.32
5	20.32	25.40
6	25.40	30.48
7	30.48	35.56
8	35.56	40.64
9	40.64	45.72
10	45.72	50.80
11	50.80	55.88
12	55.88	60.96
13	60.69	66.04
14	66.04	71.12

2	Wafer 针	Brass Tin 黄铜镀锡	N
1	Housing 基座	PA66 (UL94V-0/V-2)	1
序号	图号	名称	材料
数量	附注		

	GENERAL TOLERANCES		SCALE: 1:1	NAME	DATE
	LINEAR	ANGLES	APPROVED		
	0.0±0.30	X° REF±6°	DESIGNER		
	UNIT: MM	0.00±0.20	X° ±3°	DRAWN	肖坤权
SIZE: A4	0.000±0.10	X° X'±2°			

深圳市思拓展电子有限公司  
 SHENZHEN SINOTOP ELECTRONICS CO., LTD  
 公司网址: www.szstuo.cn 公司电话: 0755-23765350  
 邮 箱: 2850175982@qq.com 公司传真: 0755-23765341

TITLE: 508mmPITCH 90° WAFER DIP TYPE

PART. NO:	ST-WF-508-001AW
DWG. NO:	
REV:	A0
SHEET:	1/1

仅供参考

REV.	REVISION RECORD	DATE
A0	新图面发行	2017.06.16

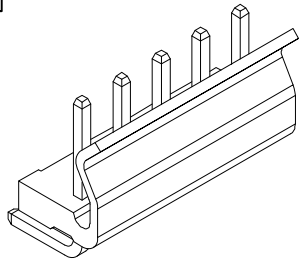

主要技术参数 Main Specifications

- 线数 (Poles): 02 to 14
- 接触电阻 (Contact resistance):  $\leq 20\text{m}\Omega$
- 绝缘电阻 (Insulation resistance):  $\geq 1000\text{M}\Omega$
- 额定电压 (Rated voltage): 250V AC DC
- 额定电流 (Rated current): 5.0A AC DC
- 耐电压 (Withstand Voltage): 1500V AC/minute
- 温度范围 (Temperature Range):  $-25^{\circ}\text{C} \sim +85^{\circ}\text{C}$

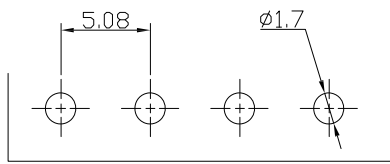
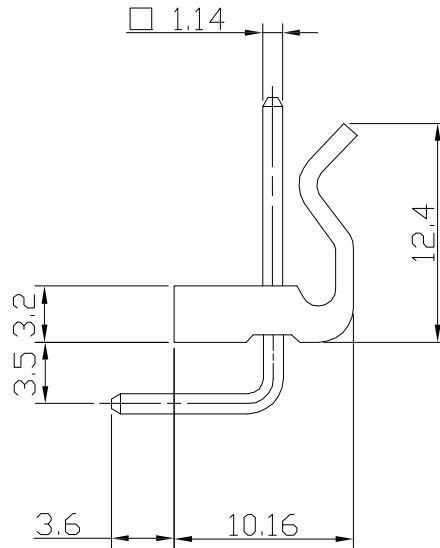
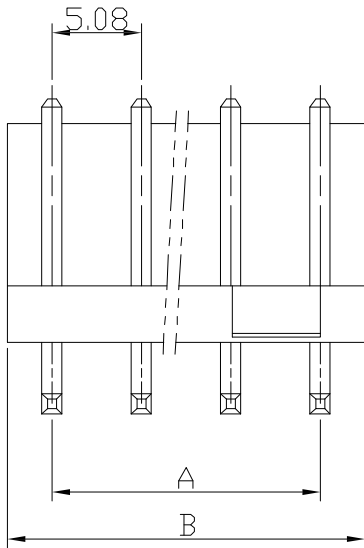

P. C. B LAYOUT

Poles	Dimensions mm	
	A	B
2	5.08	10.16
3	10.16	15.24
4	15.24	20.32
5	20.32	25.40
6	25.40	30.48
7	30.48	35.56
8	35.56	40.64
9	40.64	45.72
10	45.72	50.80
11	50.80	55.88
12	55.88	60.96
13	60.69	66.04
14	66.04	71.12

2	Wafer 针	Brass Tin 黄铜镀锡	N		
1	Housing 基座	PA66 (UL94V-0/V-2)	1	Transparent 透明白色	
序号	图号	名称	材料	数量	附注

	GENERAL TOLERANCES		SCALE: 1:1	NAME	DATE	深圳市思拓展电子有限公司 SHENZHEN SINOTOP ELECTRONICS CO., LTD 公司网址: www.szstuo.cn 公司电话: 0755-23765350 邮 箱: 2850175982@qq.com 公司传真: 0755-23765341	PART. NO:
	LINEAR	ANGLES	APPROVED				ST-WF-508-001AWG
UNIT: MM	0.0±0.30	X° REF±6°	DESIGNER			TITLE:	DWG. NO:
SIZE: A4	0.00±0.20	X° ±3°	DRAWN	肖坤权	2017.06.16	508mmPITCH 90° WAFER DIP TYPE	REV: A0
	0.00±0.10	X° X'±2°					SHEET: 1/1