

仅供参考

REV.	REVISION RECORD	DATE
A0	新图面发行	2017.06.16

主要技术参数 Main Specifications

线数 (Poles): 02 to 16
 接触电阻 (Contact resistance): $\leq 10\text{m}\Omega$
 绝缘电阻 (Insulation resistance): $\geq 1000\text{M}\Omega$
 额定电压 (Rated voltage): 250V AC DC
 额定电流 (Rated current): 3.0A AC DC
 耐电压 (Withstand Voltage): 1000V AC/minute
 温度范围 (Temperature Range): $-25^{\circ}\text{C} \sim +85^{\circ}\text{C}$

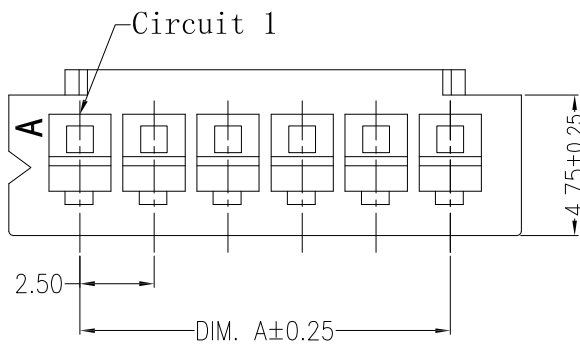
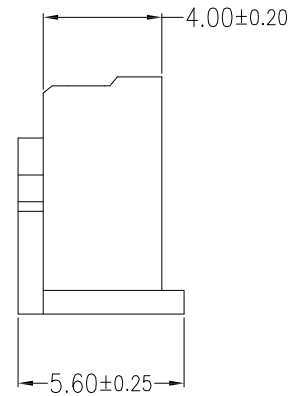
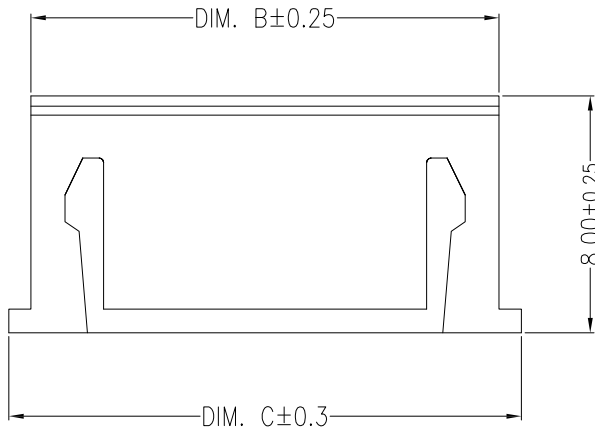
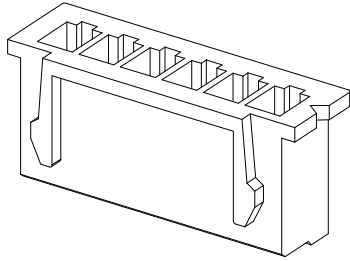

Circuits	Dimensions (mm)		
	DIM. A	DIM. B	DIM. C
02	2.50	5.80	7.30
03	5.00	8.30	9.80
04	7.50	10.80	12.30
05	10.00	13.30	14.80
06	12.50	15.80	17.30
07	15.00	18.30	19.80
08	17.50	20.80	22.30
09	20.00	23.30	24.80
10	22.50	25.80	27.30
11	25.00	28.30	29.80
12	27.50	30.80	32.30
13	30.00	33.30	34.80
14	32.50	35.80	37.30
15	35.00	38.30	39.80
16	37.50	40.80	42.30
17	40.00	43.30	44.90
18	42.50	45.80	47.30

A	HOUSING	1 PCS	PA66	COLOR:WHITE
ITFM	COMPONENT	Q'TY	MATERIAL	FINISH

	GENERAL TOLERANCES		SCALE: 1:1	NAME	DATE	深圳市思拓展电子有限公司 SHENZHEN SINOTOP ELECTRONICS CO., LTD 公司网址: www.szstuo.cn 公司电话: 0755-23765350 邮 箱: 2850175982@qq.com 公司传真: 0755-23765341	PART. NO:
	LINEAR	ANGLES	APPROVED				ST-WF-250-001Y
UNIT: MM	0.0 ± 0.30	X° REF ± 6°	DESIGNER			TITLE:	DWG. NO:
SIZE: A4	0.000 ± 0.10	X° X' ± 2°	DRAWN	肖坤权	2017.06.16	2.50mm PITCH HOUSING	REV: A0 SHEET: 1/1

仅供参考

REV.	REVISION RECORD	DATE
A0	新图面发行	2017.06.16

主要技术参数 Main Specifications

- 接触电阻 (Contact resistance): $\leq 20m\Omega$
- 绝缘电阻 (Insulation resistance): $\geq 1000M\Omega$
- 额定电压 (Rated voltage): 150V AC DC
- 额定电流 (Rated current): 3.0A AC DC
- 耐电压 (Withstand Voltage): 500V AC/minute
- 温度范围 (Temperature Range): $-25^{\circ}C \sim +85^{\circ}C$

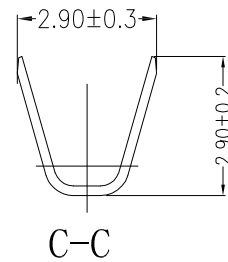
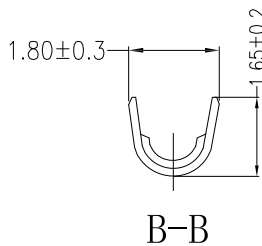
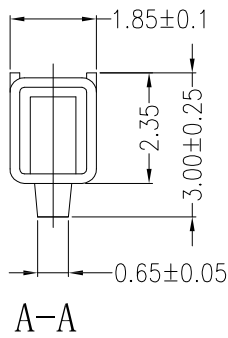
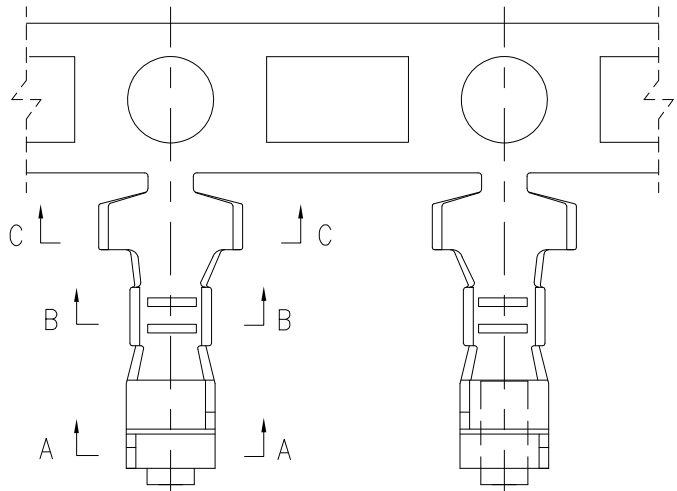
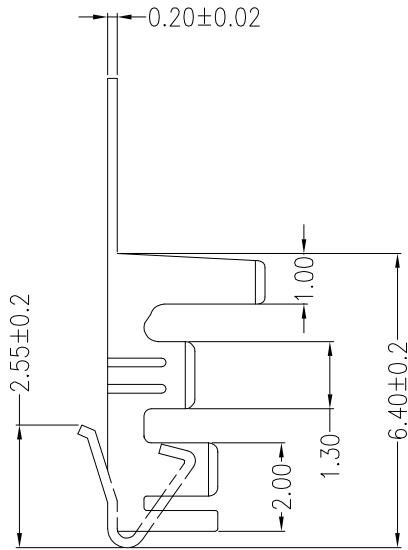

Wire Range	Insulation O. D.	Material	Finish	Qty/Reel
AWG #22~#28	1.90mm (max)	Phosphor bronze	Tin-plated	

	GENERAL TOLERANCES		SCALE: 1:1	NAME	DATE	深圳市思拓展电子有限公司 SHENZHEN SINOTOP ELECTRONICS CO., LTD 公司网址: www.szstuo.cn 公司电话: 0755-23765350 邮 箱: 2850175982@qq.com 公司传真: 0755-23765341	PART. NO: ST-WF-250-001T	
	LINEAR	ANGLES	APPROVED				DWG. NO:	
UNIT: MM	0.0±0.30	X° REF±6°	DESIGNER			TITLE:	REV: A0	SHEET: 1/1
SIZE: A4	0.000±0.10	X° X'±2°	DRAWN	肖坤权	2017.06.16	2.50mm PITCH TERMINAL		