

仅供参考

REV.	REVISION RECORD	DATE
A0	新图面发行	2017.06.16

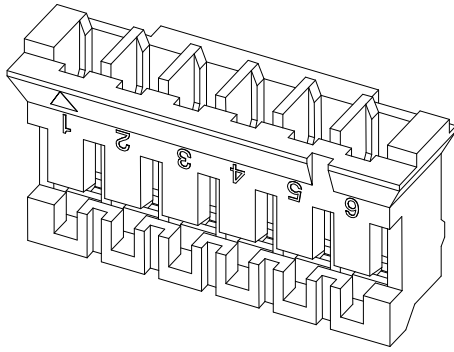

主要技术参数 Main Specifications

线数 (Poles): 02 to 16
 接触电阻 (Contact resistance): $\leq 20m\Omega$
 绝缘电阻 (Insulation resistance): $\geq 1000M\Omega$
 额定电压 (Rated voltage): 250V AC DC
 额定电流 (Rated current): 2.0A AC DC
 耐电压 (Withstand Voltage): 800V AC/minute
 温度范围 (Temperature Range): $-25^{\circ}C \sim +85^{\circ}C$

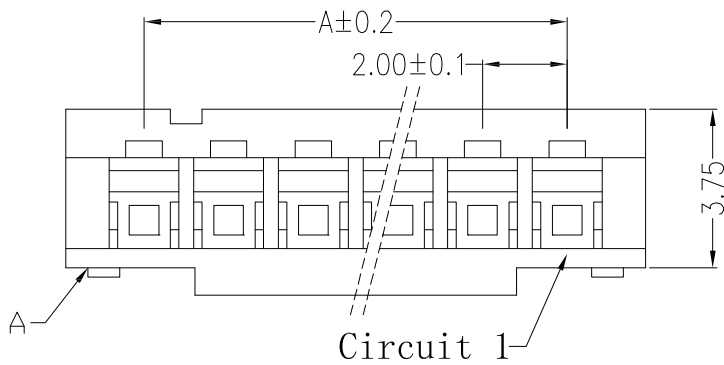
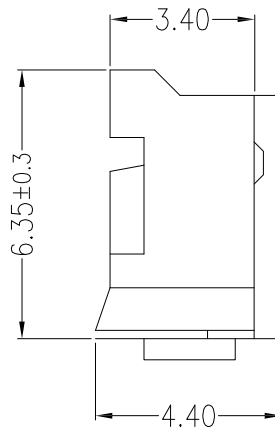
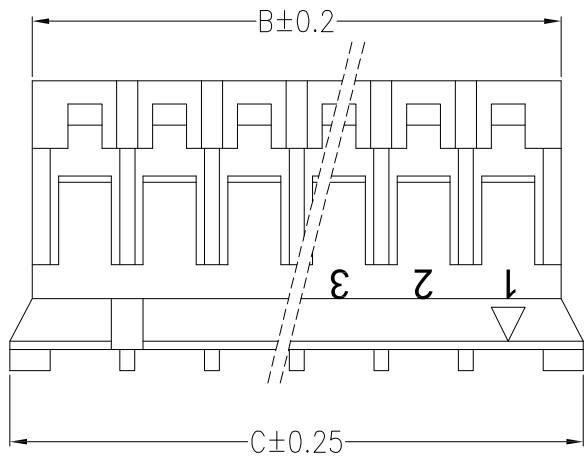

Circuits	Dimensions (mm)		
	A	B	C
02	2.00	4.50	5.70
03	4.00	6.50	7.70
04	6.00	8.50	9.70
05	8.00	10.50	11.70
06	10.00	12.50	13.70
07	12.00	14.50	15.70
08	14.00	16.50	17.70
09	16.00	18.50	19.70
10	18.00	20.50	21.70
11	20.00	22.50	23.70
12	22.00	24.50	25.70
13	24.00	26.50	27.70
14	26.00	28.50	29.70
15	28.00	30.50	31.70
16	30.00	32.50	33.70

A	HOUSING	1 PCS	PA66	COLOR:WHITE
ITFM	COMPONENT	Q'TY	MATERIAL	FINISH

	GENERAL TOLERANCES		SCALE: 1:1	NAME	DATE	深圳市思拓展电子有限公司 SHENZHEN SINOTOP ELECTRONICS CO., LTD 公司网址: www.szstuo.cn 公司电话: 0755-23765350 邮 箱: 2850175982@qq.com 公司传真: 0755-23765341	PART. NO:
	LINEAR	ANGLES	APPROVED				ST-WF-200-001Y
	0.0±0.30	X° REF±6°	DESIGNER				DWG. NO:
	UNIT: MM	0.00±0.20	X° ±3°	DRAWN	肖坤权		2017.06.16
SIZE: A4	0.000±0.10	X° X'±2°					REV: A0 SHEET: 1/1

仅供参考

REV.	REVISION RECORD	DATE
A0	新图面发行	2017.06.16

主要技术参数 Main Specifications

- 接触电阻 (Contact resistance): $\leq 20m\Omega$
- 绝缘电阻 (Insulation resistance): $\geq 1000M\Omega$
- 额定电压 (Rated voltage): 150V AC DC
- 额定电流 (Rated current): 3.0A AC DC
- 耐电压 (Withstand Voltage): 500V AC/minute
- 温度范围 (Temperature Range): $-25^{\circ}C \sim +85^{\circ}C$

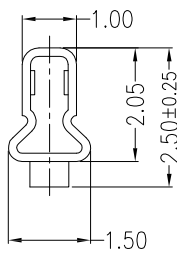
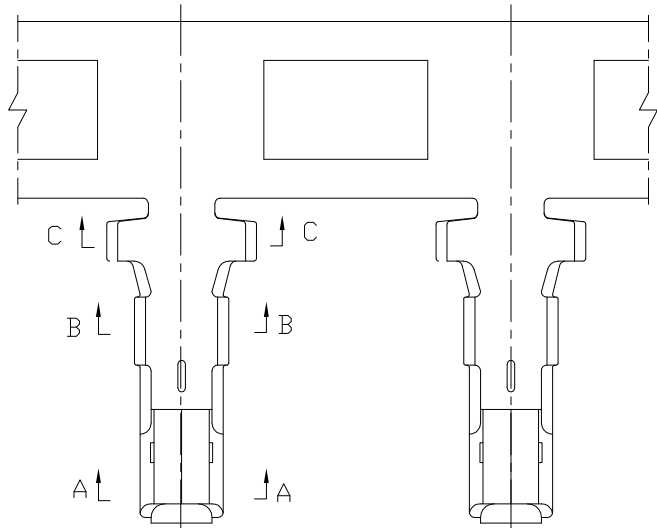
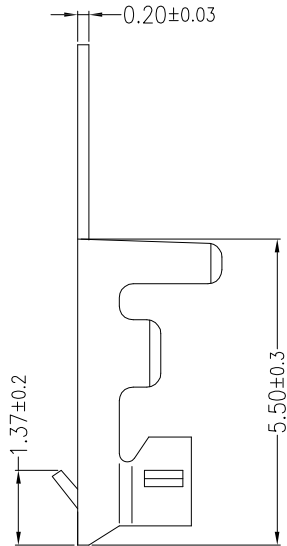

A-A

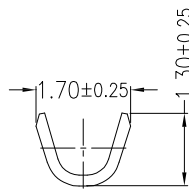

B-B

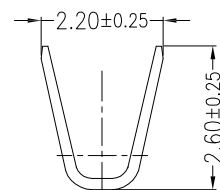

C-C

Wire Range	Insulation O. D.	Material	Finish	Qty/Reel
AWG #24~#32	1.60mm (max)	Phosphor bronze	Tin-plated	

	GENERAL TOLERANCES		SCALE: 1:1	NAME	DATE	深圳市思拓展电子有限公司 SHENZHEN SINOTOP ELECTRONICS CO., LTD 公司网址: www.szstuo.cn 公司电话: 0755-23765350 邮 箱: 2850175982@qq.com 公司传真: 0755-23765341	PART. NO: ST-WF-200-001T	
	LINEAR	ANGLES	APPROVED				DWG. NO:	
UNIT: MM	0.0±0.30	X° REF±6°	DESIGNER			TITLE:	REV: A0 SHEET: 1/1	
SIZE: A4	0.000±0.10	X° X'±2°	DRAWN	肖坤权	2017.06.16	2.00mm PITCH TERMINAL		